

## A/133/V High Temperature, Watercooled Piezoelectric IEPE Triaxial Accelerometer

1mV/g up to 250mV/g  $\pm 10\%$  38gms  
900°C max surface temperature *with water flow*



A/133/V-3

A/133/V-10

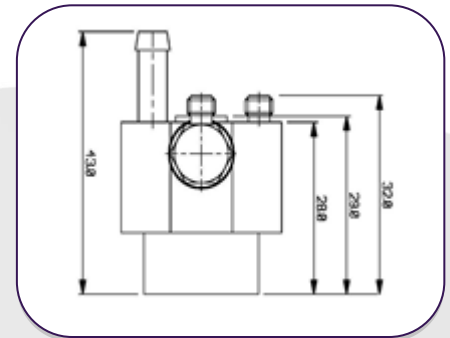
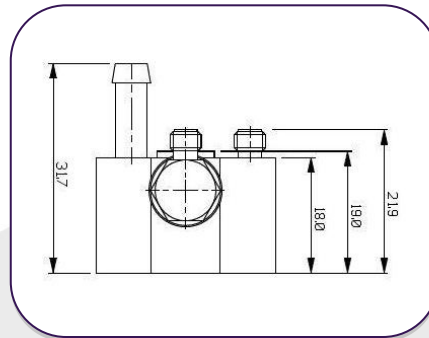
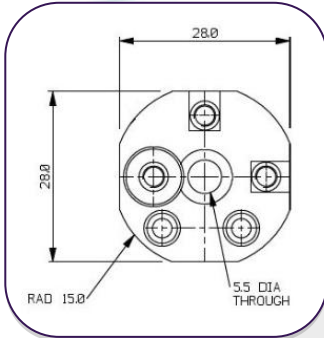

### Typical Frequency Response

The A/133/V IEPE range of voltage triaxial accelerometers feature ultra high temperature usage on surfaces up to 900°C. Developed as solutions for Vibration Measurements on exhaust pipes or engine turbo collectors, they have since found uses in many other high temperature test applications.

Mono-axial versions can also be supplied on request, axis selection to suit customer application.

Water flow is via two titanium pipes and it's recommended that the flow rate of 0.5 litres/min is maintained permanently when in use at high temperature. Failure to do so could lead to injury and damage to the unit.

It is recommended at the highest temperatures a constant supply of chilled cooling water should be used.

The A/133/V consists of 3 mono axial voltage accelerometers mounted into an anodized aluminium block. This allows the advantage of single axis repair if required.

Accessories:  
Silicone tubing  
General purpose 12V pump

X

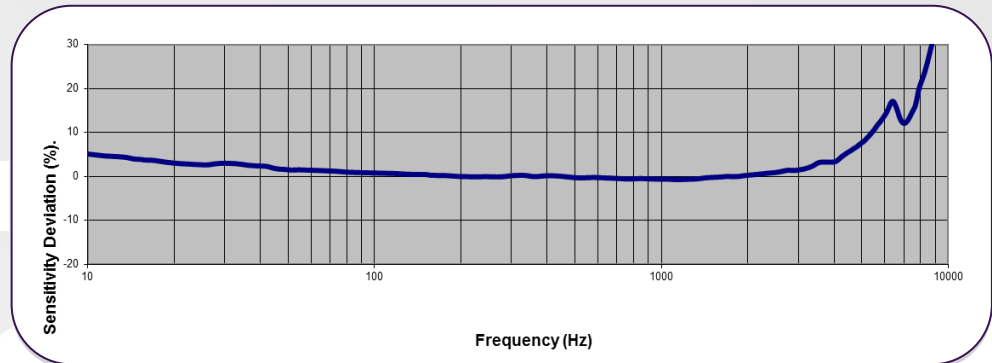

Y

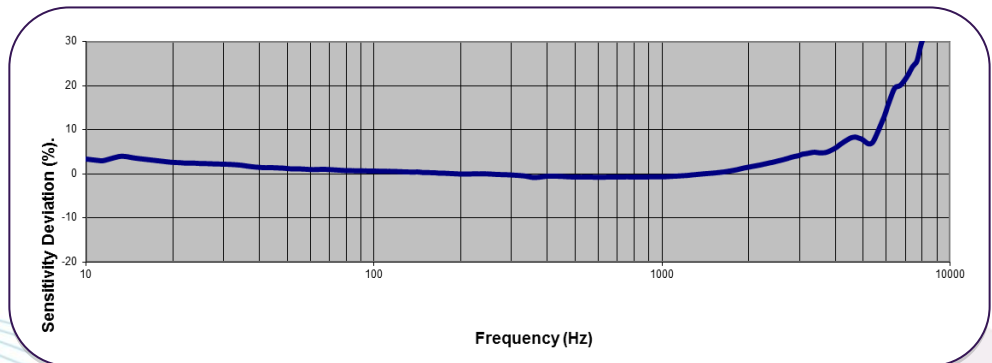

Z

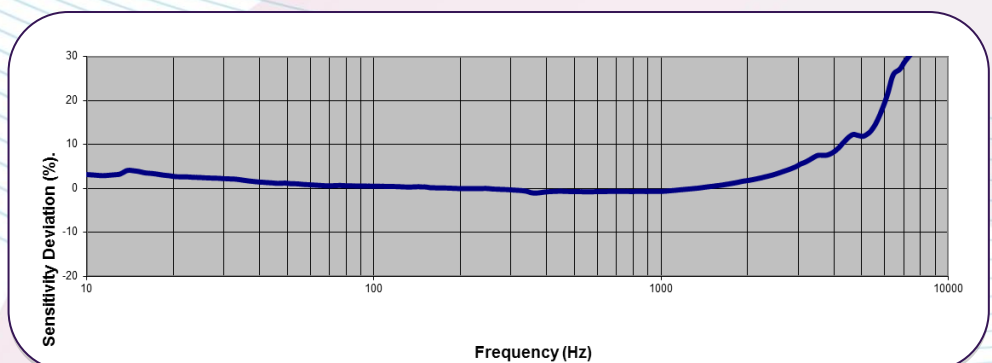

## A/133/V High Temperature, Watercooled Piezoelectric IEPE Triaxial Accelerometer

1mV/g up to 250mV/g  $\pm 10\%$  38gms  
900°C max surface temperature *with water flow*



### Temperature Response

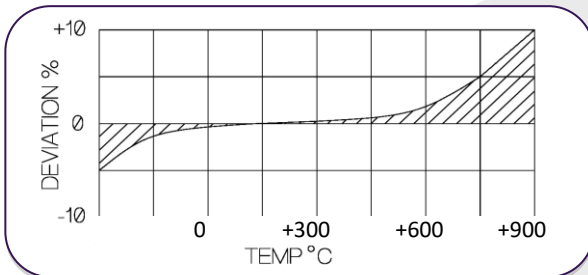

### Spectral Noise

1Hz	761 $\mu\text{g}/\sqrt{\text{Hz}}$
10Hz	193 $\mu\text{g}/\sqrt{\text{Hz}}$
100Hz	37.8 $\mu\text{g}/\sqrt{\text{Hz}}$
1kHz	11.2 $\mu\text{g}/\sqrt{\text{Hz}}$
10kHz	4.2 $\mu\text{g}/\sqrt{\text{Hz}}$

	Metric		Imperial	
Voltage sensitivity $\pm 10\%$	10 mV/(m/s <sup>2</sup> )	100 mV/(m/s <sup>2</sup> )	10 mV/g	100 mV/g
Typical Frequency Range	1Hz – 4kHz $\pm 5\%$ 0.7Hz – 5kHz $\pm 10\%$		1Hz – 4kHz $\pm 5\%$ 0.7Hz – 5kHz $\pm 10\%$	
Resonant Frequency KHz	$\approx 15$		$\approx 15$	
Cross Axis error % max	5		5	
Temperature Range °C Without water flow With water flow	-50/ +125°C +900°C (surface temp)		-58/ +257°F +1652°F (surface temp)	
Max continuous accn. g sine	4,903m/s <sup>2</sup>		500g	
Supply voltage VDC	15/35		15/35	
Supply current mA	2/20		2/20	
Bias voltage VDC (20°C)	$\approx 9.5$		$\approx 9.5$	
Setting time to 90% final val. Secs	$\approx 1$		$\approx 1$	
Noise level equiv. mg	3		3	
L.F corner frequency, Hz	0.7		0.7	
Case seal	Welded hermetic connector		Welded hermetic connector	
Case Material	Inserts s/steel 303 S31 Mtg. block anodised al. alloy		Inserts s/steel 303 S31 Mtg. block anodised al. alloy	
Connector	Microdot skt 10/32 UNF		10-32 UNF Microdot	
Weight	38gms		1.34oz	

### DJB Instruments (UK) Ltd

Finchley Avenue,  
Mildenhall, Suffolk IP28 7BG

**Tel** +44 (0)1638 712 288  
**Email** sales@djbinstruments.com  
**Web** www.djbinstruments.com

A UK company with UK-based manufacturing, assembly and calibration in-house.

DJB Iss.3

